

INSTALLATION GUIDE

SOFTBED HT 4GS ■ 8GS

The HT 4GS and 8GS soft beds have been developed for use in concrete high stalls with a slight slope and self-supporting dividers. They consist of a rubber cover sheet and special composite foam sheets developed for dairy farming.



For assembly you need

- ✓ Chalk or pencil for marking (if necessary, chalk line)
- ✓ Tensioning device incl. chain hoists/tensioning straps
- ✓ Drilling machine with 8 mm and 10 mm drill bits
- ✓ Tape measure or metre rule for measuring
- ✓ Impact drill with 8 mm drill bit
- ✓ Hammer
- ✓ Knife



Fastening elements

- ✓ Nail plug A2 8x80 with washer (approx. 8 pcs./m)



Requirements substrate/concrete

- ✓ Level, firm, clean, dry and free of holes and bumps. elevations.



Requirements for walkway covering

- ✓ The cover sheet must have been stored on the installation surface for at least 48 hours or at room temperature for 7 days before installation so that the cover sheet reaches a uniform temperature.
- ✓ At ambient temperatures below 10 degrees Celsius, the installation must not be carried out.

1 Lay out foil

To protect the composite foam panels from wetness & moisture, they must be wrapped in foil (thickness min. 100 µm). Spread the foil on the concrete so that the ends of the foil can be glued to the top of the composite foam panels overlapping (min 300 mm) to make them watertight. This step is omitted if you use foil-wrapped composite foam panels.

SOFTBED HT

4GS ■ 8GS

2 Lay out composite foam sheets and wrap in foil

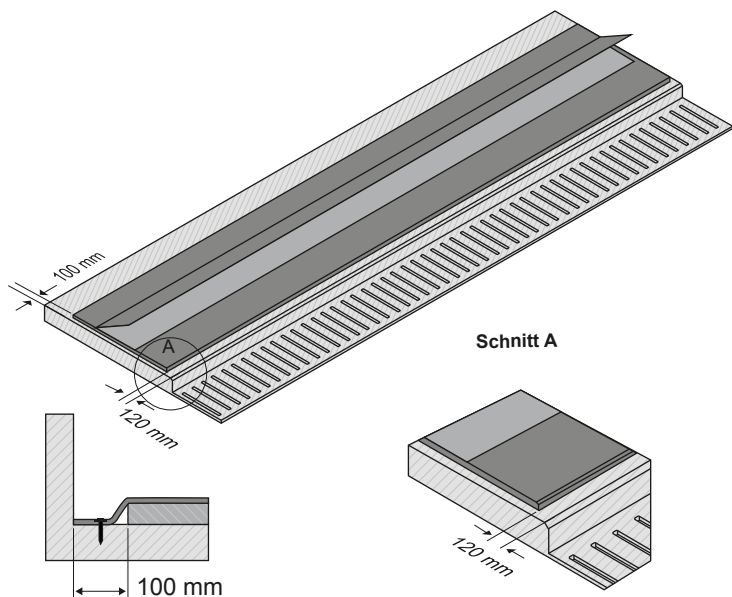

The composite foam panels are laid out with a distance of approx. 120 mm to the rear concrete edge. You need a distance of approx. 100 mm at the left and right ends. Then glue the foil to the composite foam panels.

Tip: Mark the distance in the rear area over the entire length, e.g. with a chalk line.

Note: The composite foam panels must lie close together. The following applies to composite foam panels individually wrapped in foil: The foil of the precisely cut composite foam panel must be glued watertight.

3 Unroll and align the cover sheet

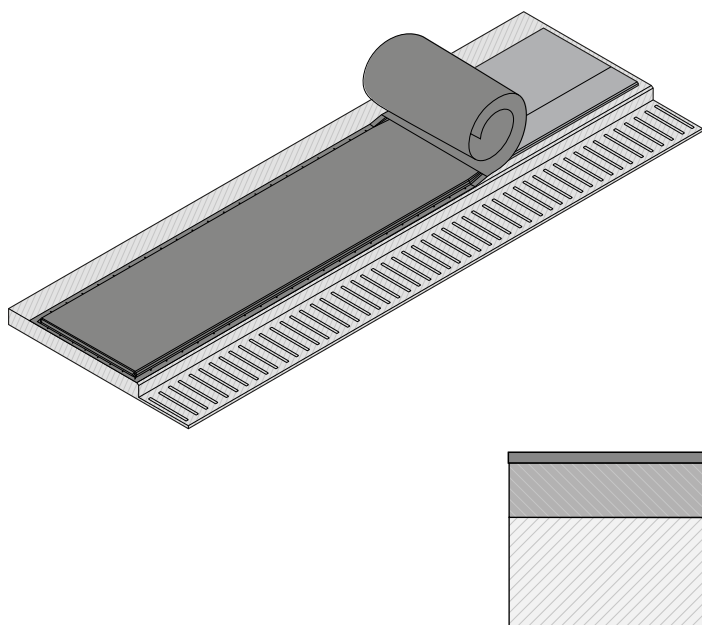

Unroll the composite foam panels and align them with a distance of 20 mm to the rear edge of the concrete.

Note: If it is not possible to unroll the cover sheet over the slabs due to the installation, the unrolled sheet can also be pulled into position. Care must be taken not to damage the sheeting. The position of the composite foam sheets should then be checked.

SOFTBED HT

4GS ■ 8GS

4 Fixing the cover sheet to one end face

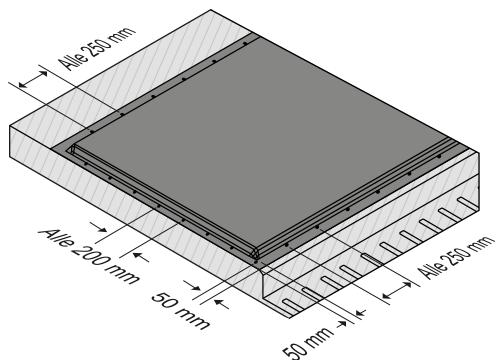

For fixing, holes are drilled in the cover sheet and the concrete. The distance to the edge of the cover sheet on the front side is 50 mm. The distance in the head and foot area is also 50 mm to the edge of the cover sheet. In between, further holes are drilled every approx. 200 mm and then the A2 8 x 80 nail plugs with washers are driven in.

Steps

- A** Pre-drill the cover sheet \varnothing 10 mm
- B** Drill a hole in the concrete \varnothing 8 mm
- C** Insert the plastic dowels flush into the holes in the cover sheet. Drive in A2 8 x 80 nails with washer flush.
- D** In the head and foot area, place 2 more A2 8 x 80 nail plugs at a distance of 300 mm and 550 mm from the face. to the front side.

5 Pretensioning the cover sheet



The cover sheet must be prestressed by 11.5 % (1 % corresponds to 100 mm per 10 m). The tensioning device should distribute the exerted tension over the whole width on the cover sheet. For example, use 2 rails (one on the top side, the second on the bottom side of the deck). Chain hoists or tension belts can be used for tensioning.

Note: If necessary, the cover sheet must be cut to the final length in an intermediate step. This means tensioning, measuring, relaxing, cutting to length and tensioning again.

6 Fix the cover sheet to the second fix on the second side

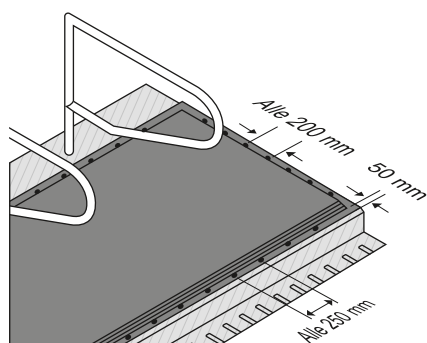

For fixing, holes are drilled in the cover sheet and the concrete. The distance to the edge of the cover sheet on the front side is 50 mm. The distance in the head and foot area is also 50 mm to the edge of the cover sheet. In between, further holes are drilled every approx. 200 mm and then the A2 8 x 80 nail plugs with washers are driven in.

Steps

- A** Pre-drill the cover sheet \varnothing 10 mm
- B** Drill hole in the concrete \varnothing 8 mm
- C** Insert plastic dowels flush into the holes in the cover sheet. Drive the A2 8 x 80 nails with washer flush.
- D** In the head and foot area, place 2 more A2 8 x 80 nail plugs at a distance of 300 mm and 550 mm from the face. to the front side.

SOFTBED HT

4GS ■ 8GS

7 Fixing the cover sheet in the head and foot area

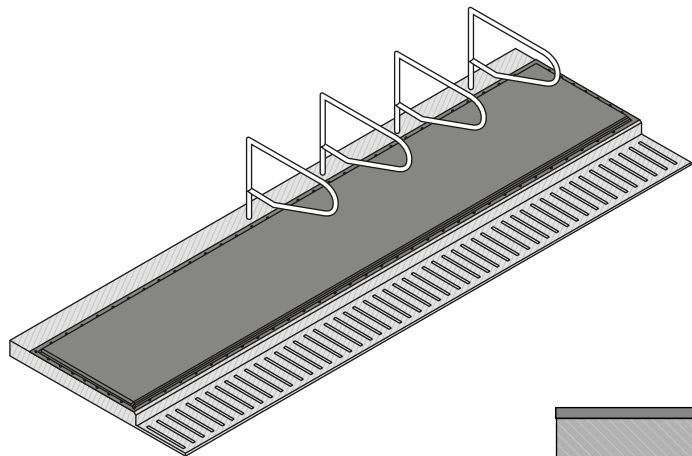

To finally fix the cover sheet, additional nail plugs A2 8 x 80 are installed in the head and foot area every approx. 250 mm. The distance to the edge of the cover sheet is approx. 50 mm in each case.

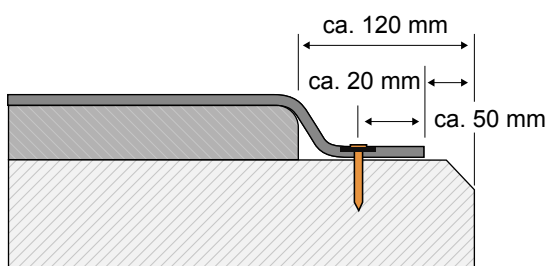

Care and maintenance instructions

The rubber surfaces must be cleaned regularly. The cleaning agents must not attack the rubber surface. The rubber surface must be kept dry with suitable bedding material.

Note: Proper installation may vary due to local conditions.
No manufacturer's liability in case of installation damage.