



The HT KombiBox is a combination of a soft bed in the head section, consisting of a composite foam and the Huber Technik 8GS cover sheet and the deep pen in the udder area. The type of bedding can therefore be selected as required.

REQUIREMENTS

Surface/Concrete

- Level, firm, clean, dry and free of holes and protrusions.

Cover sheet

- The covering sheet must have been stored on the installation surface for at least 48 hours or 7 days at room temperature before installation to ensure that the covering sheet reaches a uniform temperature.
- Installation must not be carried out at ambient temperatures below 10 degrees Celsius.

For assembly you need

- Drill with Ø 10 mm drill bit
- Impact drill with Ø 8 mm drill bit for concrete
- Measuring tape / metre rule
- Hammer
- Knife

Fastening elements

- Nail plug A2 8X80

Installation

From the inside edge of the bedding border approx. 800 mm to the start of the composite foam plate. Lay the foam plates (size 1600 x 1000 x 40 mm) lengthways. Then align the second foam plate 800 mm wide (100 mm indented) to the lower plate. Roll out cover sheet 8GS (1300 mm wide) in the centre over the foam bed.

Fastening

Fasten at the front with a washer max. every 200 mm, fasten at the rear with an angle strip every 200 mm and 38 mm from the edge. Do not hammer in too hard -> There must be no tension, the rubber covering must not bulge!

Bedding material

Use sufficient and suitable material e.g. chopped straw, substrate...

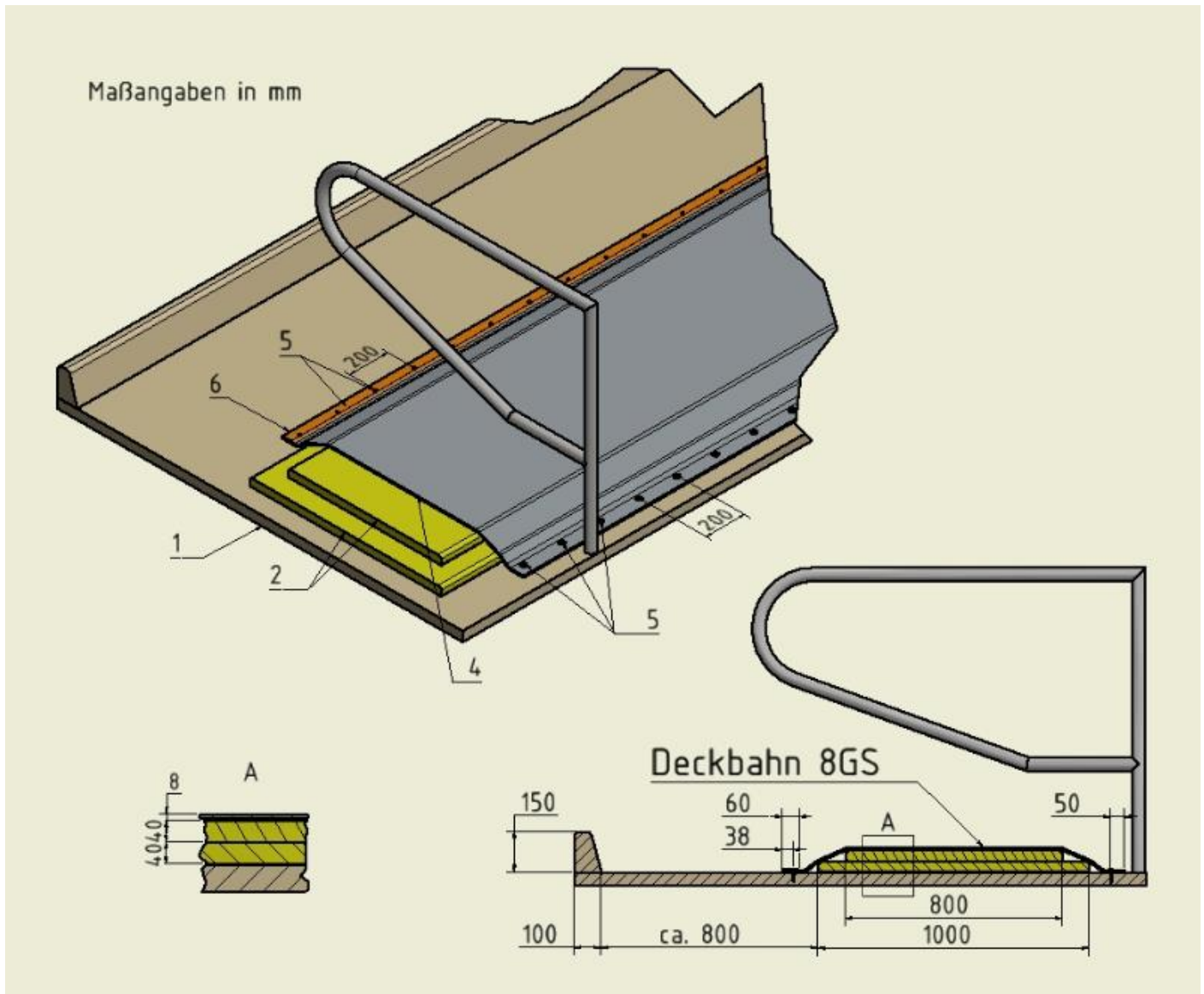





Legend: 1 concrete, 2 composite foam, 4 cover sheet 8GS, 5 fastening, 6 angle strips

Care and maintenance instructions

The rubber surfaces must be cleaned regularly. The cleaning agents must not attack the rubber surface. The rubber surface must be kept dry with suitable bedding material.

Note: Proper installation may vary depending on local conditions.
The manufacturer is not liable for installation damage.

Follow us on   

 www.cow-comfort-huber.com

Huber Technik Vertriebs GmbH

△ Robert-Bosch-Str. 8 · 85435 Erding

☎ +49 8122 869 122 · ✉ vertrieb@huber-technik.de